

**DIRECTIONAL CONTROL VALVE SOLENOID OPERATED
TYPE HD3-ES-*/20
CETOP 03 - 32 MPa**

19mm Coil Stems

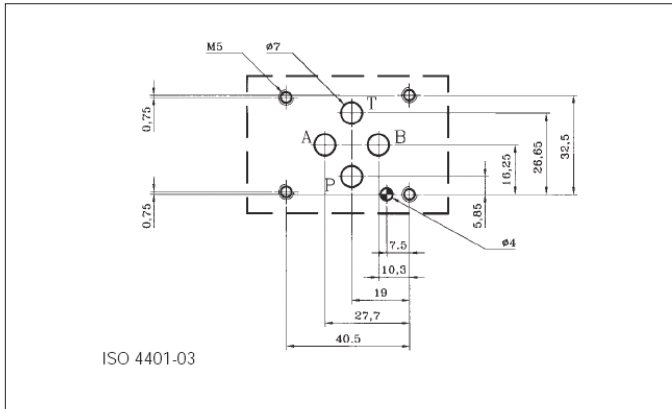

1 HOW TO READ THE MODEL CODE FOR HD3-ES - Pressure 32 MPa (320 bar)

HD3 - ES - (1) (C) - * - (024C) (-) / 20
 ① ② - ③ ④ - ⑤ - ⑥ ⑦ ⑧

- ① **HD3** : 4-way directional control valve CETOP 03
- ② **ES** : electrically controlled
- ③ **(1)** : spool type (see [5])
- ④ **(C)** : solenoid(s) and spring(s) arrangements (see [5])
 - C : 2 solenoids, spool is spring centered (3 position)
 - LL : 1 solenoid, spool is spring offset (2 position)
 - ML : 1 solenoid, spool is spring centered(2 position)
- ⑤ ***** : Code reserved for options and variants
 - S-** : calibrated orifice on P port, see [14]
 - K : water proof caps on emergency pin, see [13]
- ⑥ **(024C)** : Electric voltage and solenoid coils
 - 0000 : no coil(s)
 - 012C : coil(s) for V12DC
 - 024C : coil(s) for V24DC
 - 115A : coil(s) for V110/50 – V 115/60 AC
 - 230A : coil(s) for V220/50 – V 230/60 AC
- ⑦ **-** : Coil connection
 - : DIN 43650-A ISO 4400
 - AMP : Amp Junior Timer – vertical configuration, see [15]
 - AMPX : Amp Junior Timer – axial configuration, see [15]
 - D : Deutsch, see [15]
- ⑧ **20** : Design number (progressive) of the valves.

2 DESCRIPTION

The spool ⑤ shifts into the valve body ① subject to the action of springs ④ and solenoids ⑨. Spool ⑤, depending from its shape and its position in the valve body ①, opens and/ or closes passages between P, A, B and T ports, thus controlling the direction of the hydraulic flow.

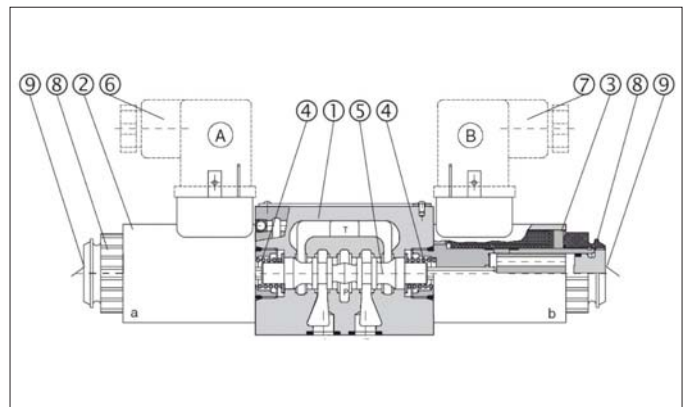

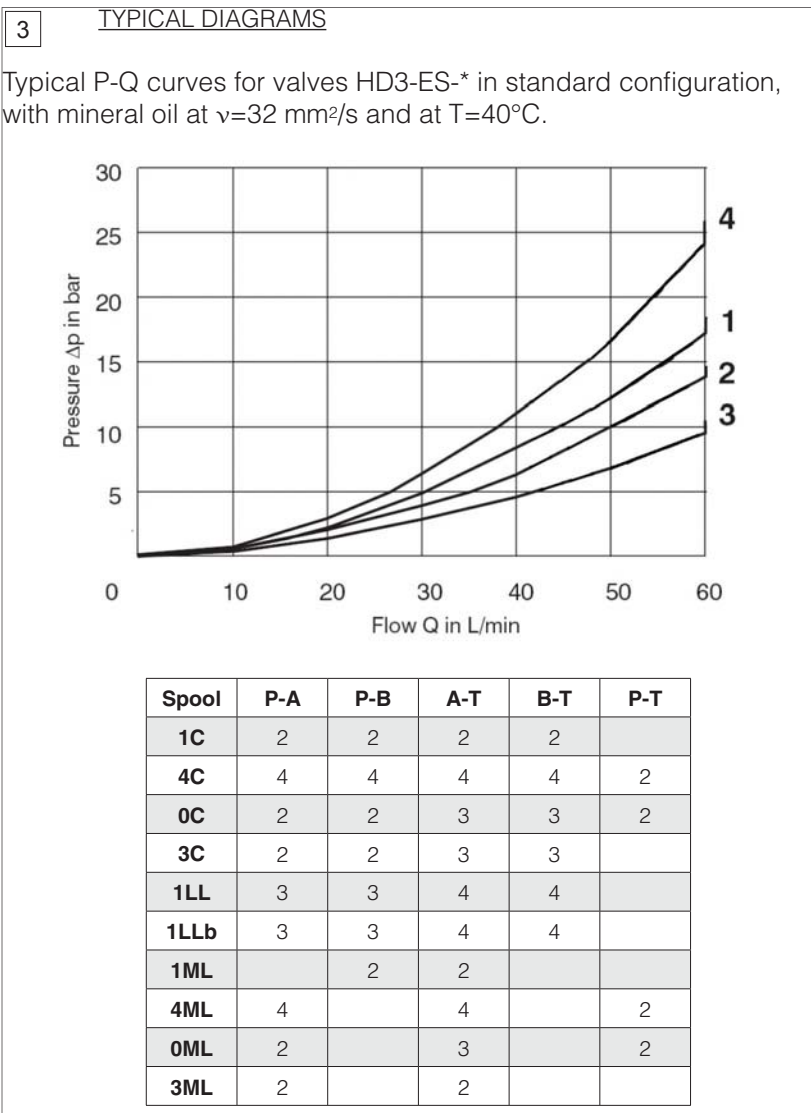

4 TECHNICAL DATA

Nominal flow	50 l/min
Maximum rec. flow rate see 7	60 l/Min
Maximum nominal pressure (P, A, B)	32 MPa (320 bar)
Maximum pressure at T port	21 MPa (210 bar)
Pressure drops	see 3
Electric characteristics	see 6
Protection to DIN 40050	IP 65
Duty cycle	100%
Dimensions	see 9
Installation	see 8
Mass	1,6/1,2 kg

6 ELECTRIC CHARACTERISTICS

Valve type HD3-ES-* are operated by solenoid that are energized :

- directly from a D.C. voltage supply
 V 12 DC = 012C
 V 24 DC = 024C
- by the use of coils that incorporate a full wave bridge rectifier, from A.C. voltage supply :

V 110/50 - V 115/60 = 115A
 V 220/50 - V 230/60 = 230A
 Other available voltages are : 014C ; 048C ; 060C ; 102C ; 205C ; and V24/50 = 024A

5 SPOOL IDENTIFICATION AND INTERMEDIATE POSITION TRANSITORIES

Functional Symbols					
Designation	Symbol	Interposition	Designation	Symbol	Interposition
1C			1ML		
4C			0ML		
0C			1MLb		
3C			1LLb		
1LL			4MLb		
3ML			0MLb		
4ML			3MLb		

All connectors must conform to ISO 4400 (DIN 43650) and electric circuitry must be able to carry the following rated current values :

V 12 DC = 2,4 A V 115/50 = 0,26 A
 V 24 DC = 1,2 A V 230/50 = 0,14 A

Coils with 2 electric pins, conforming with AMP connectors, are only available for DC supply (example of code : B02-012C AMP).

Permissible supply voltage variation : $\pm 10 \%$

7 HYDRAULIC LIMITS OF USE

P-Q characteristics limits for safe use of HD3-ES-* solenoid operated valves. Measured at $v = 32 \text{ mm}^2/\text{s}$ and $T = 40^\circ\text{C}$

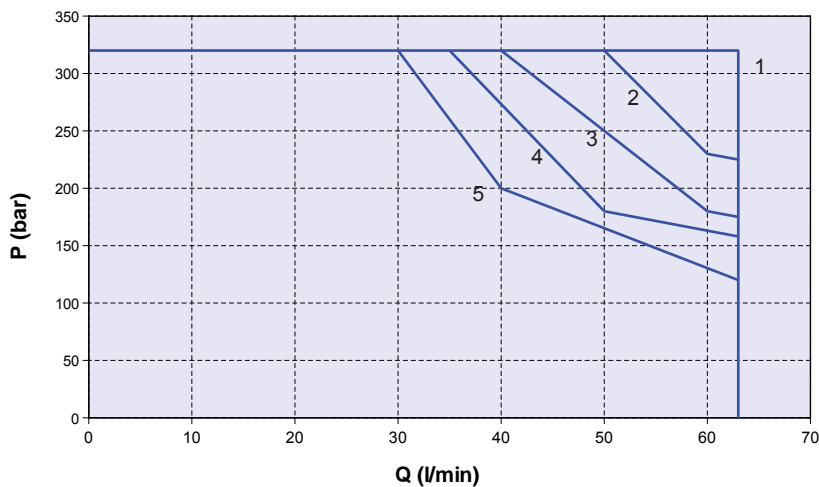

1C	1
4C	5
0C	1
3C	2
1LL	3
3ML	2
4ML	5
1ML	1
0ML	1
1MLb	1
1LLb	3
4MLb	5
0MLb	1
3MLb	2

8 INSTALLATION

All valves HD3-* conform with ISO and CETOP specifications for mounting surface dimensions (see 9) and for valves height. When assembled to its mounting plate valve HD3-* must be fastened with 4 bolts M5x45 (or M5x** according to the number of modules) tightened at 8 Nm torque. Leakage between valve and mounting surface is prevented by the positive compression on their seats of 4 seals of Quad Ring type 9,25x1,68x1,68.

10 SOLENOID

Solenoid valves can be supplied without electric coils, as HD3-ES-****-0000.

Coils are supplied separately ; standard, 3 electric pins, coils are :

- B02-012C ; B02-024C
- B02-115A ; B02-230A

Connections to the electric supply is made by standard 3-PIN connectors, according to ISO 4400 (DIN 43650).

Connectors can be with different cable exit size (PG9, PG11) and beside of the plain connecting function they may incorporate various features like

- Signal led
- Voltage surge suppressor, etc.

11 HYDRAULIC FLUID

Seals and materials used on standard valves HD3-* are fully compatible with hydraulics fluids of mineral base, upgraded with antifoaming and anti oxidizing agents.

The hydraulic fluid must be kept clean and filtered to ISO 4406 class 19/17/14, or better, and used in a recommended viscosity range from 10 cSt to 60 cSt.

9 INSTALLATION DIMENSIONS

(dimensions are mm)

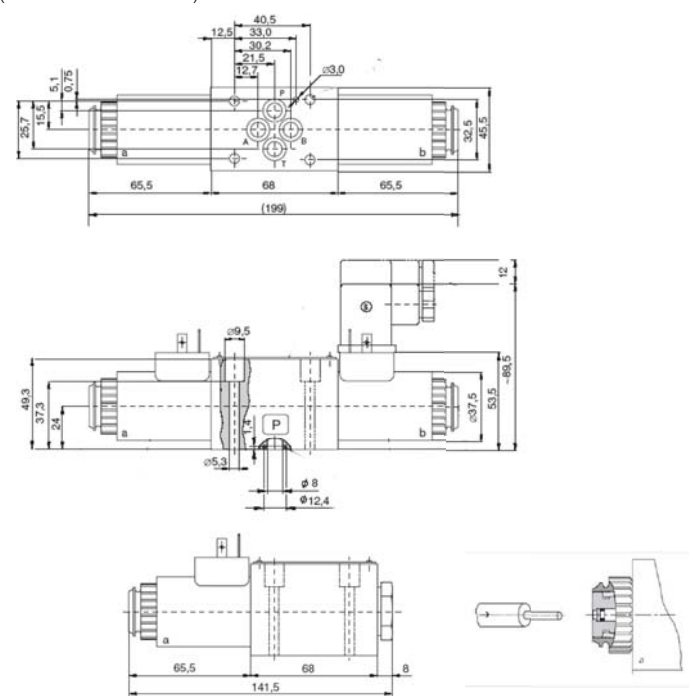

12

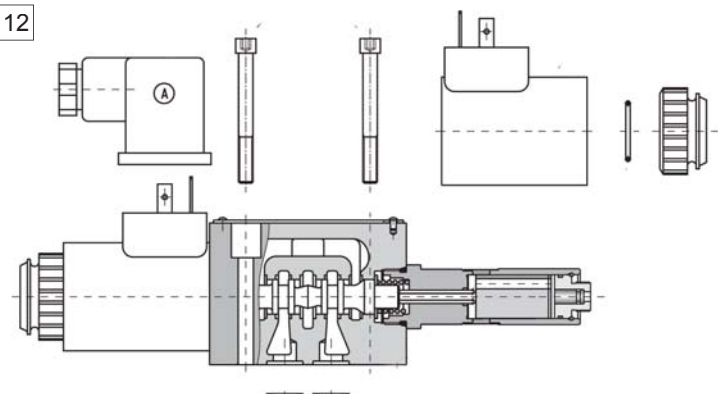

13 VERSION "K": OVERRIDE PIN

Solenoid valves according to "K" version have extended emergency actuator pins protruding from the solenoid shape, that permit a quick and easy "hand operation" of the valves, without the need of any tool. The actuator pin and the end of the solenoid are protected by a flexible rubber cap that makes easy operation and protects from moisture and water splashes.



standard manual override



Version "K" Override pin

14 VERSION "S*": CALIBRATED ORIFICE ON P PORT

Option "S*" is represented by an element suitably shaped to be inserted on P port of the solenoid valve, having a calibrated orifice (of various sizes) able to restrict, depending on the ΔP value, the flow rate entering the solenoid valve.

Those elements have the following orifice diameters :

- 3S-00 → D = 0 mm
- 3S-10 → D = 1,0 mm
- 3S-15 → D = 1,5 mm
- 3S-20 → D = 2,0 mm
- 3S-25 → D = 2,5 mm

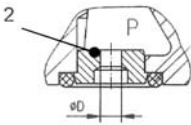

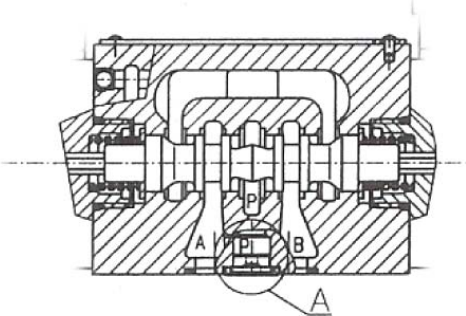

and are kept sealed on the P port of the valve by an OR of 9,25x1,78 mm sizes (example OR 110-2037)

15 SPECIAL COIL CONNECTIONS

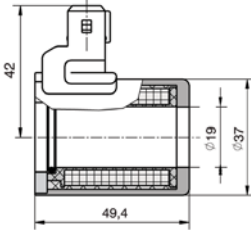

AMP = Amp Junior Timer
vertical configuration

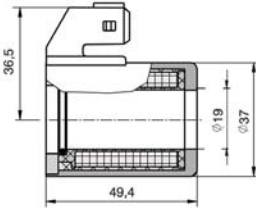

AMPX = Amp Junior Timer
axial configuration

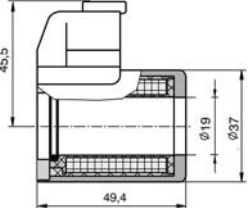

D = Deutsch

16 QUENCHING DIODE

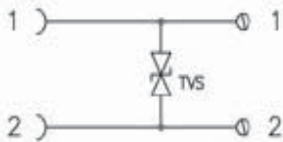

On request, coils can be supplied with an integrated bidirectional quenching diode (transil type BZW06-19B) able to provide high overvoltage protection. Their instantaneous response to transient overvoltages makes them particularly suited to protect voltage sensitive devices.