

**DIRECTIONAL CONTROL VALVES
SOLENOID OPERATED – CETOP 02
TYPE HD2 – EI - ***

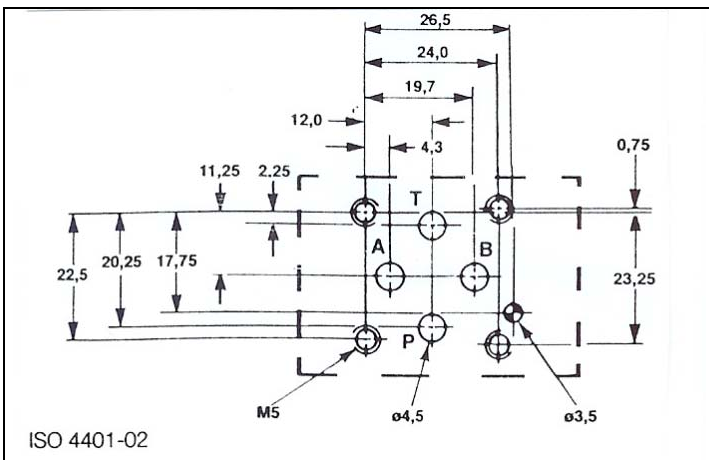

2 FUNCTIONAL SYMBOLS

Spring/Stroke combination for spool type "1"

1C

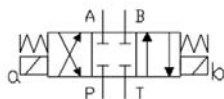

1LL

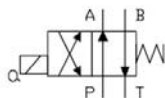

1LLb

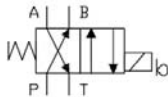

1ML

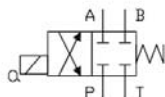

1MLb

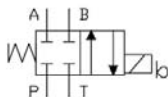

1 HOW TO READ THE MODEL CODE FOR VALVES HD2-*

HD2 - EI - (1) (C) * - (024C) / 10
 ① ② ③ ④ ⑤ ⑥ ⑦

- ① **HD2** : 4-way directional control valve Cetop 02
- ② **EI** : electrically controlled
- ③ **(1)** : spool type (see 7)
- ④ **(C)** : solenoid(s) and spring(s) arrangement, see also functional symbols 2.
 - C : 2 sol., spool is spring centered (3 position)
 - LL : 1 sol. (a), spool is spring offset (2 position, end to end)
 - ML : 1 sol. (a), spool is spring offset (2 position, middle to end)
- ⑤ ***** : Code reserved for option and variants
 - b : only for version LL, ML
 - sol. b installed (instead of sol. a)
- ⑥ **(024C)** : Electric voltage and solenoid coils
 - 0000 : no coil(s)
 - 012C : coil(s) for V12DC
 - 024C : coil(s) for V24DC
 - 110R : coil(s) for V98DC (V110/50 – V115/60 RAC)
 - 220R : coil(s) for V198DC (V220/50 – V230/60 RAC)
- ⑦ Design number (progressive) of the valves

3 DESCRIPTION

The spool ⑫ shifts in to the valves body ⑪ subject to the action of springs ⑬ and solenoids ① ②.

Spool ⑫, depending from its shape and its position in the valves body ⑪, opens and/or closes passages between P, A, B, T ports, thus controlling the direction of the hydraulic flow.

Solenoids ① and ② are energized by electric current flowing-in through connectors; in case of electric cut-offs, the spool can be manually shifted by acting on the emergency pins ⑤, located at the end of the solenoids and accessible through the retaining nuts ⑩

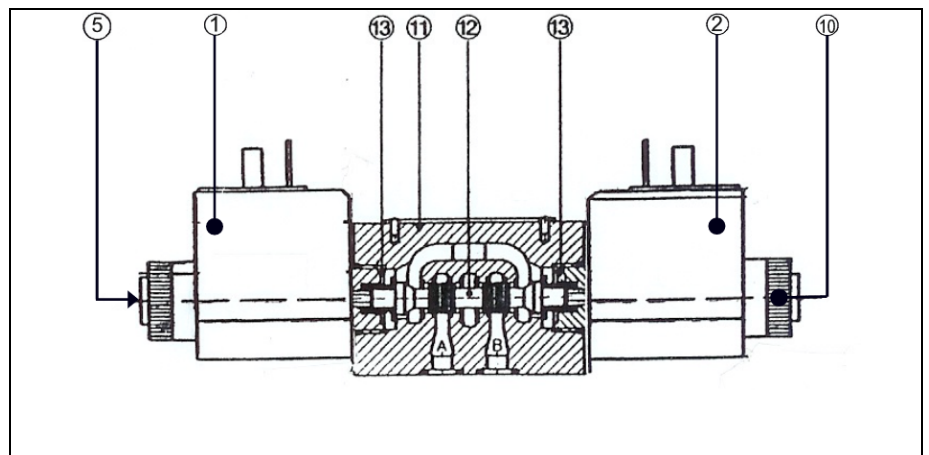

4 TYPICAL DIAGRAMS

Typical Δp -Q curves for valves HD2 - EI - * in standard configuration, with mineral oil at 36 cSt and at 50°C for flow P → A/B, A/B → T

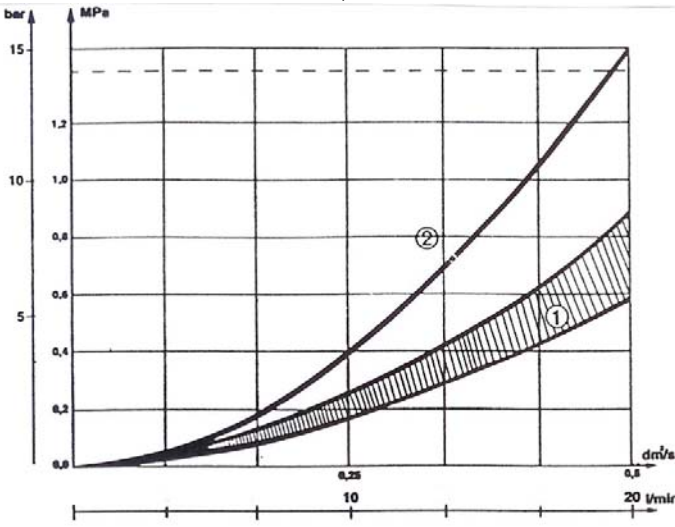

① = all spool P → A/B and A/B → T
 P → T spool 4
 ② = P → A/B spool 4
 P → T spool 4

7 SPOOL IDENTIFICATION AND INTERMEDIATE POSITION TRANSITORIES

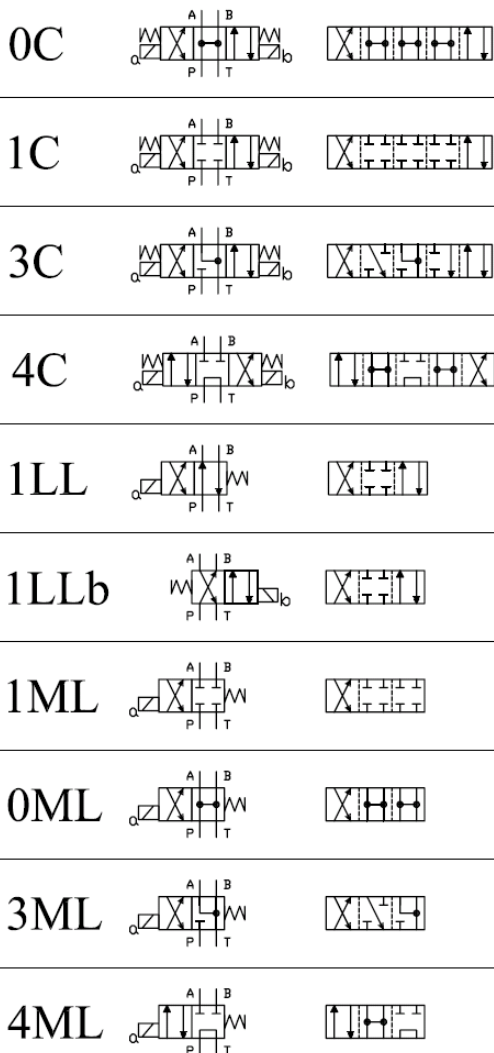

5 TECHNICAL DATA

nominal flow	20 l/min
maximum	
rec. flow rate	25 l/min
nominal pressure (P,A,B)	25 MPa (250 bar)
max pressure	32 MPa (320 bar)
maximum pressure at T port	160 MPa (160 bar)
pressure drops	see 4.
electric characteristics	see 6.
protection to DIN 40050	IP 65
duty cycle	100%
service life	≥ 10 ⁷ cycles
dimensions	see 10
installation	see 11
mass	approx 0,8/1,1 kg

6 ELECTRIC CHARACTERISTICS

Valves type HD2-EI-* are operated by solenoid that are energized:

- directly from D.C. voltage supply:
 V 12 DC (012C)
 V 24 DC (024C)
- by the use of connectors that incorporate a full wave bridge rectifier, from A.C. voltage supply:
 V 110/50, V 115/60 or V 115/50 (110R)
 V 220/50, V 230/60 or V 230/50 (220R)

All connectors must conform to ISO 4400 (DIN 43650) and electric circuitry must be able to carry the following rated current values:

- V 12 DC = 2,4 A
- V 24 DC = 1,2 A
- V 110 R = 0,30 A
- V 220 R = 0,15 A

Permissible supply voltage variation: +5% -10%.

8 FUNCTIONAL SYMBOLS

Spools, springs and solenoids combination permit to obtain almost every type of ports (P, A, B, T) connection and sequence.

For almost all types of solenoids/springs combination and for all type of spools (with the exception of spool 4), when solenoid "a" is energized, hydraulic connections are P → B and A → T; to obtain P → A and B → T solenoid "b" must be energized.

The hydraulic connections that are obtained in the "central" (neutral) position when solenoids are not energized is the characteristic mark of the spool shape and from it derives its identification number:

- 0 = P, A, B, T connected
 - 1 = P, A, B, T closed
 - 3 = P closed, A, B, T, connected
- for other types see 7.

10 INSTALLATION

All valves HD2 - * conform with ISO and CETOP specifications for mounting surface dimensions (see also front page) and for valves height. When assembled to its mounting plate valve HD2 - * must be fastened with 4 bolts M5 x 35 mm (or M5 x ** according to the number of modules) tightened at 8 Nm torque.

Leakage between valve and mounting surface is prevented by the positive compression on their seats of 4 seals of QUAD/O Ring type 7,65x1,68x1,68.

Connections to the electric supply is made by standard 3-PIN connectors, according to ISO 4400 (DIN 43650).

Connectors can be with different cable exit size (PG9, PG11) and beside of the plain connecting function they may incorporate various features like

- signal led
- bridge rectifier for AC supply
- voltage surge suppressor, etc.

11 HYDRAULIC FLUIDS

Seals and materials used on standard valves HD2 - * are fully compatible with hydraulic fluids of mineral oil base, upgraded with antifoaming and antioxidantizing agents.

The hydraulic fluid must be kept clean and filtered to ISO 4406 class 19/17/14, or better, and used in a recommended viscosity range from 10 cSt to 60 cSt.

9 INSTALLATION DIMENSIONS

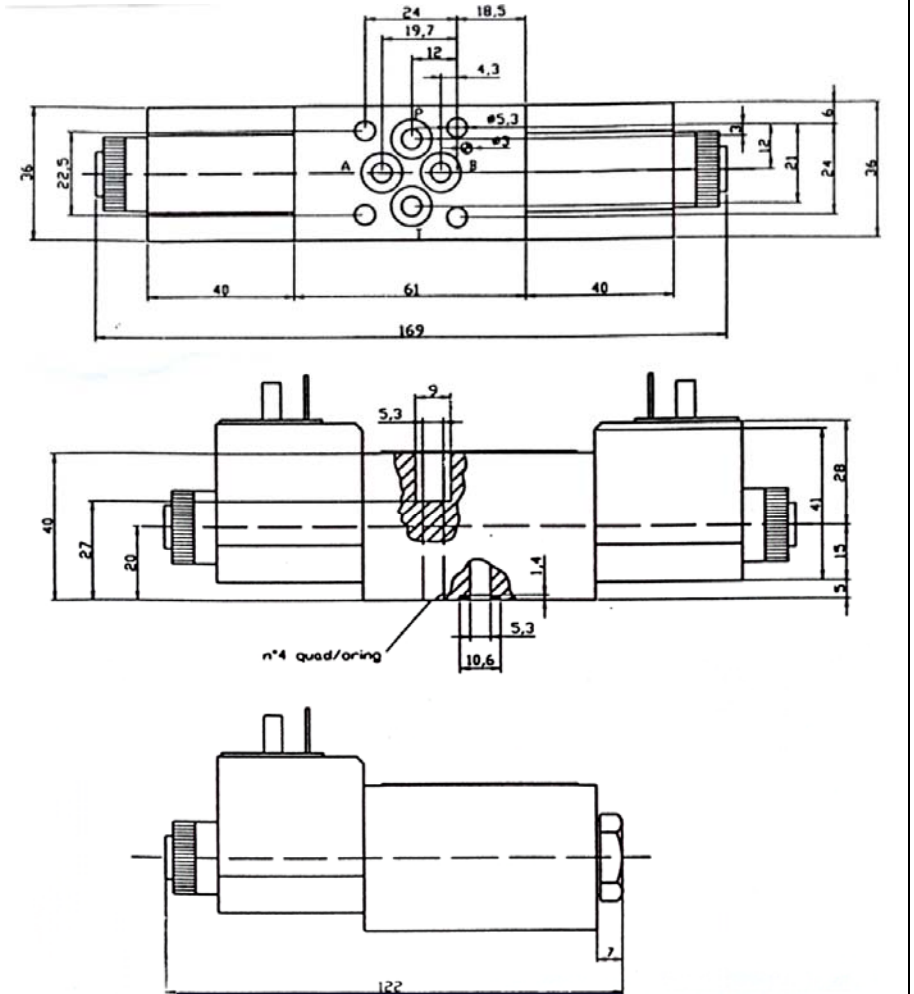

All dimensions are in mm.

12

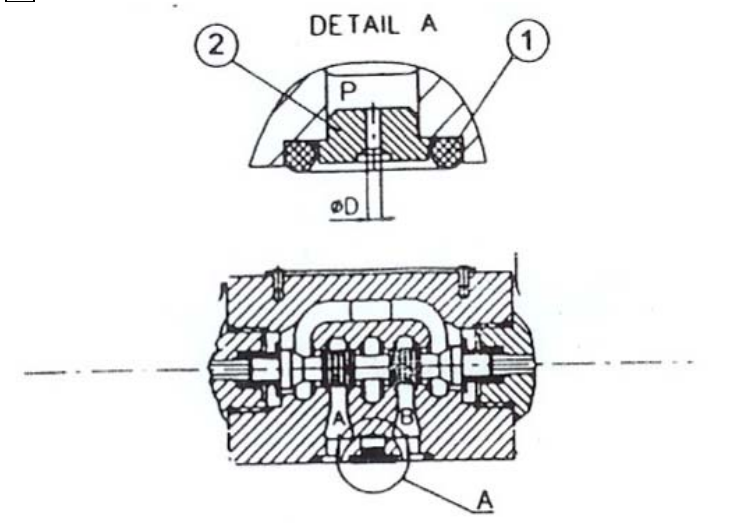

12 VERSION "S*": CALIBRATED ORIFICE ON P PORT

Option "S*" is represented by elements ②, suitably shaped to be inserted on P port of the solenoid valve, having a calibrated orifice (of various sizes) able to restrict, at the requested ΔP value, the flow rate entering the solenoid valve.

Those elements have the following orifice diameter:

2S - 08 \rightarrow D = 0.8 mm

2S - 10 \rightarrow D = 1 mm

2S - 12 \rightarrow D = 1.2 mm

2S - 15 \rightarrow D = 1.5 mm

and are kept sealed on the P port of the valve by an OR ① of 7.65x1.78 mm sizes (example OR 107-2031).